

Copyright NEO - DYNE BV
www.neo-dyne.com
Leemansweg 27G, 6827 BX
The Netherlands

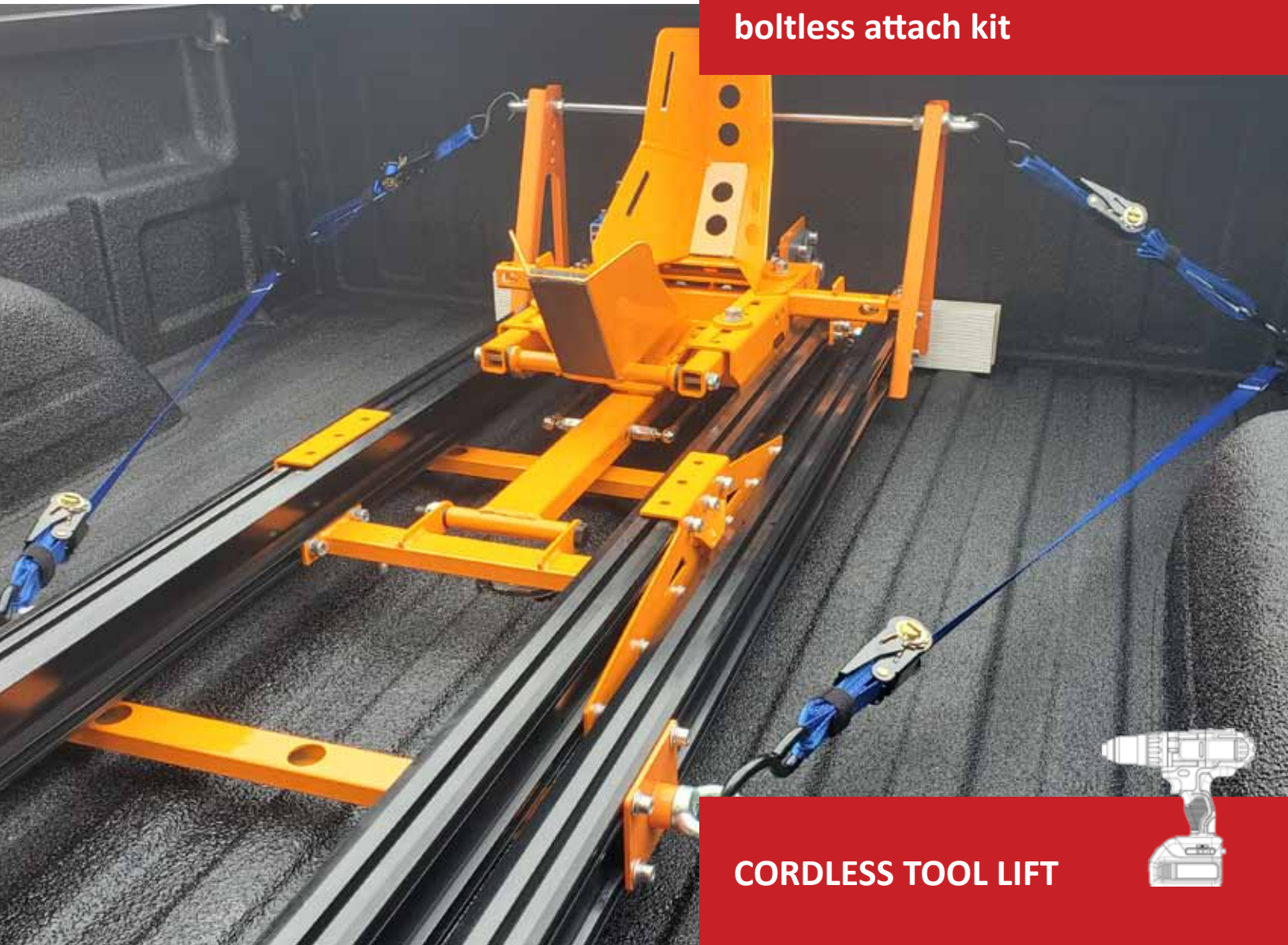

MOTORCYCLE & UNIVERSAL LOADERS

INSTALLATION GUIDE AC 012 boltless attach kit



CORDLESS TOOL LIFT

PARTS SUPPLIED WITH AC 012 KIT, PRINCIPLE	3
ATTACHING BRACKETS AND PADS	4
USING AC 012 IN PICK-UP TRUCKS	16
USING IN VANS	17
PAD PLACEMENT	19

TOOLS NEEDED:

- 19MM WRENCH
- ALLEN WRENCH FOR 10 + 8MM BOLTS



AC 012 - BOLTLESS ATTACH KIT

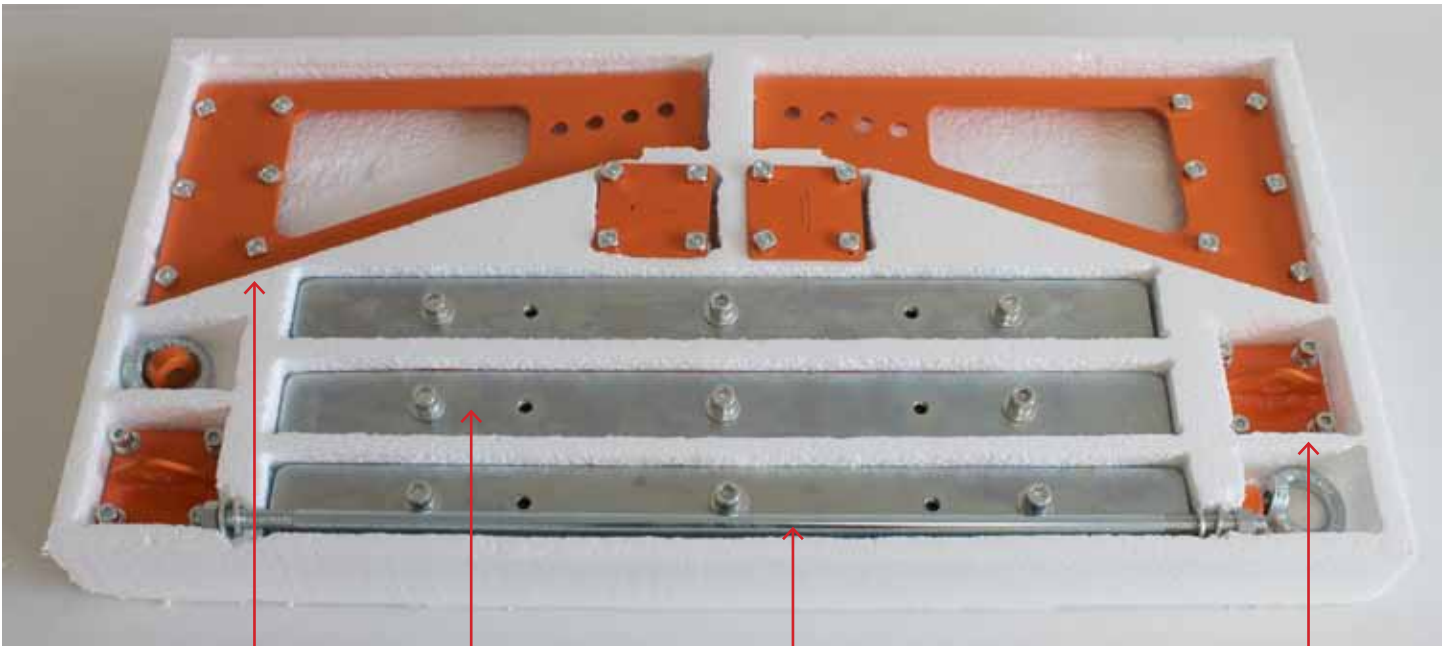

2 pcs front brackets

3 pcs polyurethane pads

2pcs M12 rings, 1 pcs M12 rod

4 pcs side brackets

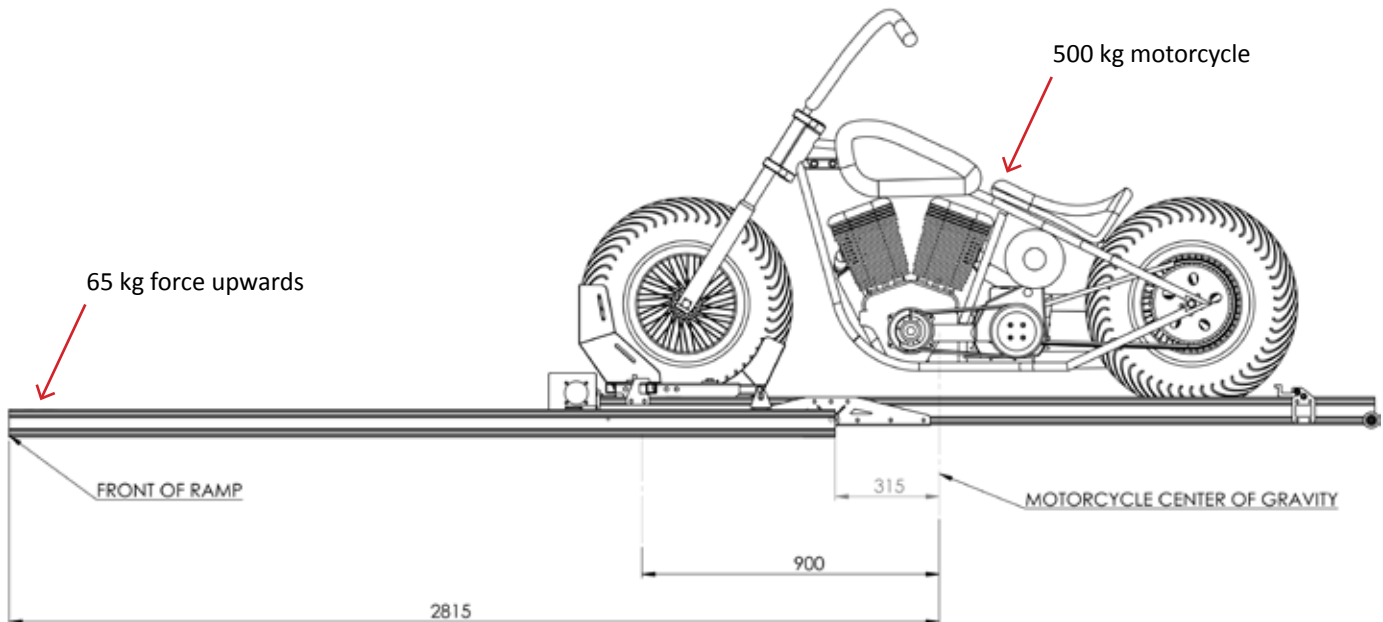

Forces on AC 012

Typically when loading a heavy motorcycle (500 kg), its center of gravity is around 350mm behind the ramp's rear edge. If a 500kg motorcycle is lifted when using the AC 012, the upward force on the front of the ramp is only 65kg. The straps are made for 400kg loads EACH, therefore the safety factor is 800 kg divided by 65 kg - safety factor 12:1.



M8 square nuts

M8 bolts

LOOSEN BOLTS

Loosen the M8 bolts on the main bracket so that the M8 square nut can slide through the aluminium rails. Loosen to obtain a gap of 3-4 mm.

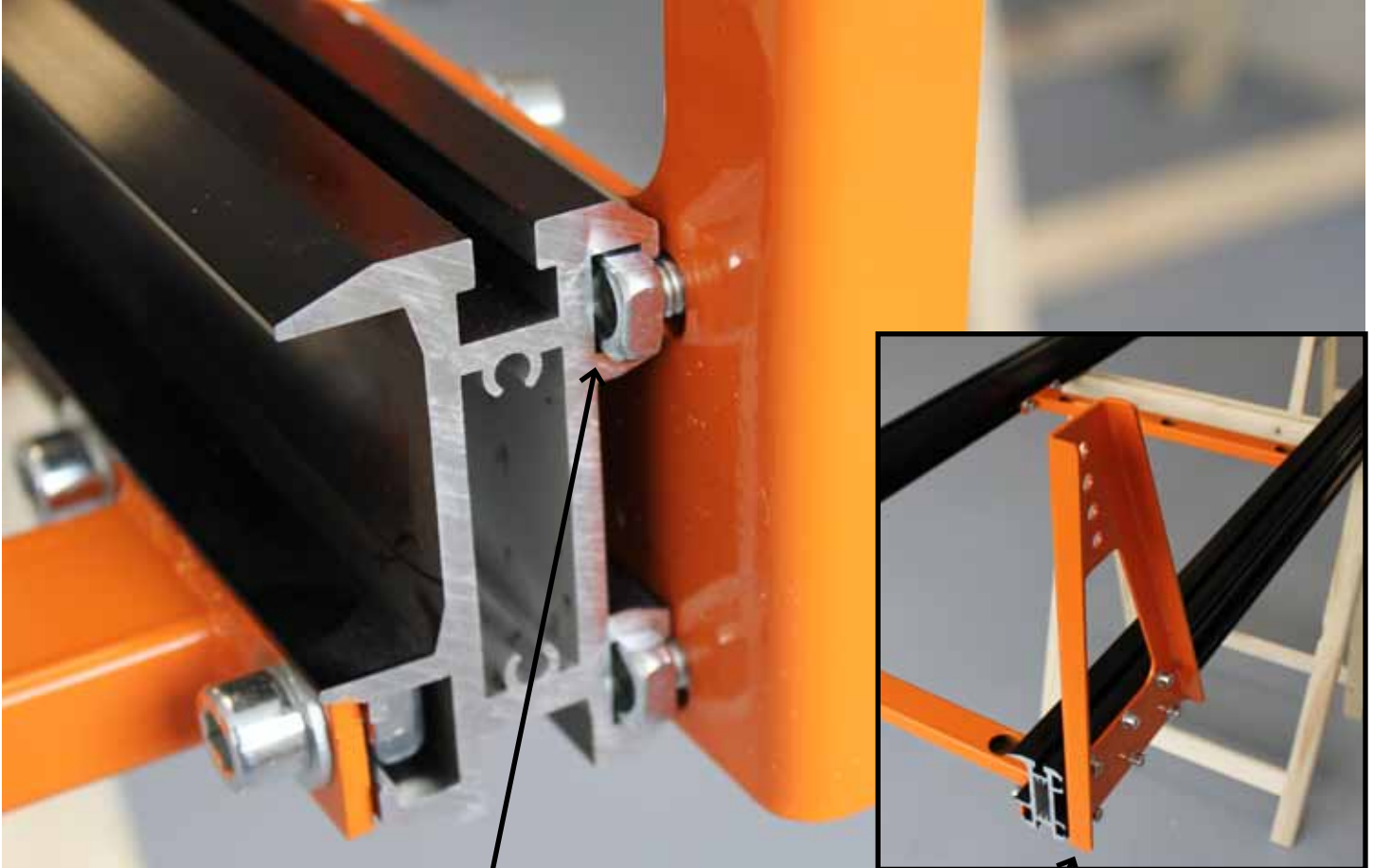

Nut slides through groove

Vertical side of bracket towards
the front of the ramp

SLIDE BRACKET INTO RAMP GROOVES

The bracket must be installed with the vertical side towards the front of the ramp. After you loosened the bolts, slide now the bracket through the rail until its front side is flush with the end of the rail. Tighten the bolts.



12 mm rod

SLIDE 12 MM ROD THROUGH BRACKET

Place the washers and the nut like on page 7 and slide the 12mm rod through the bracket. Let it hang like that.



flat washer, spring washer and nut

NUT AND WASHERS

Place the nut and the washers like in the picture above.



12mm rod in the other bracket

SLIDE 12 MM ROD THROUGH THE OTHER BRACKET

Place the washers and the nut in mirror image compared to the other side. First slide the 12mm rod end through the bracket. Then slide the bracket through the rail and lock the M8 bolts.

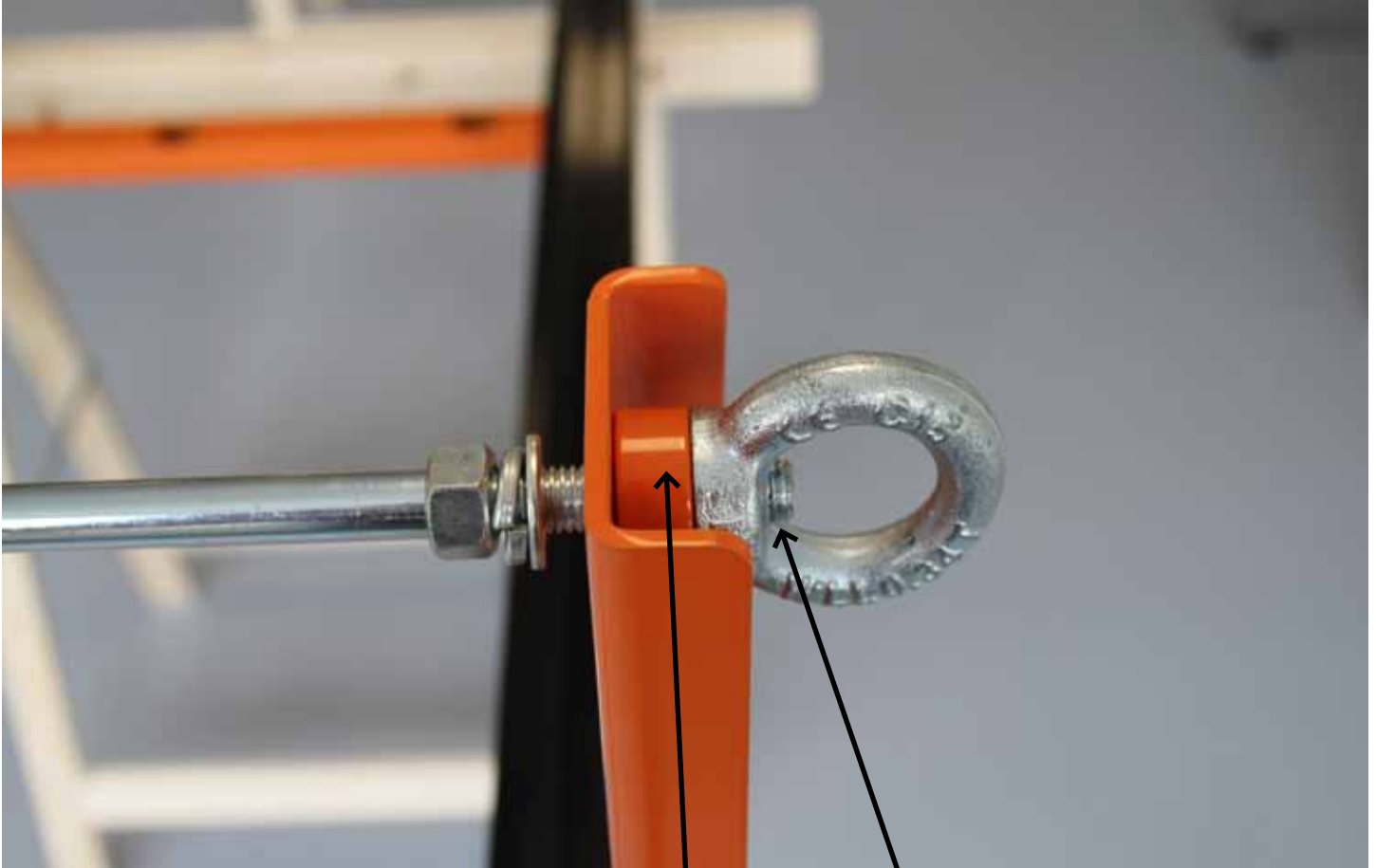

Spacer

M12 thread shows

SPACER AND EYE BOLT

First slide the spacer on the rod end. Then screw the M12 eye bolt (ring) to the threaded section. do not tighten yet, and do the same thing on the other side. You will notice that a small part of the thread is showing, about 5mm of it. That is normal.



Tighten tne nut

TIGHTEN NUT

Hold the eye bolt and tighten the M12 nut using a 19mm wrench. Repeat on the other side.



Side bracket

ATTACH SIDE BRACKETS

Loosen the bolts on the side brackets so that they can slide through the rails. One bracket should be placed in the middle of the ramp, and the other one 200mm from the rear end. Tighten the bolts. Note that depending on the placement of the tie-down points in your vehicle, you may need to re-position these.



Blue color pad

Tighten pad bolts

ATTACH FRONT PAD

There are two blue pads and one red. The blue pads to be attached to the front and rear frame joiners, using the bolts provided. First, attach the front pad under the front joiner and tighten the bolts.



Blue color pad

ATTACH REAR PAD

Attach the rear pad under the roller bracket of the ramp.



Red pad

ATTACH RED PAD

The red pad is slightly firmer than the blue pads. Attach it to the second joiner from the back of the ramp. This joiner may later be re-positioned when installing the ramp on a pick-up truck.

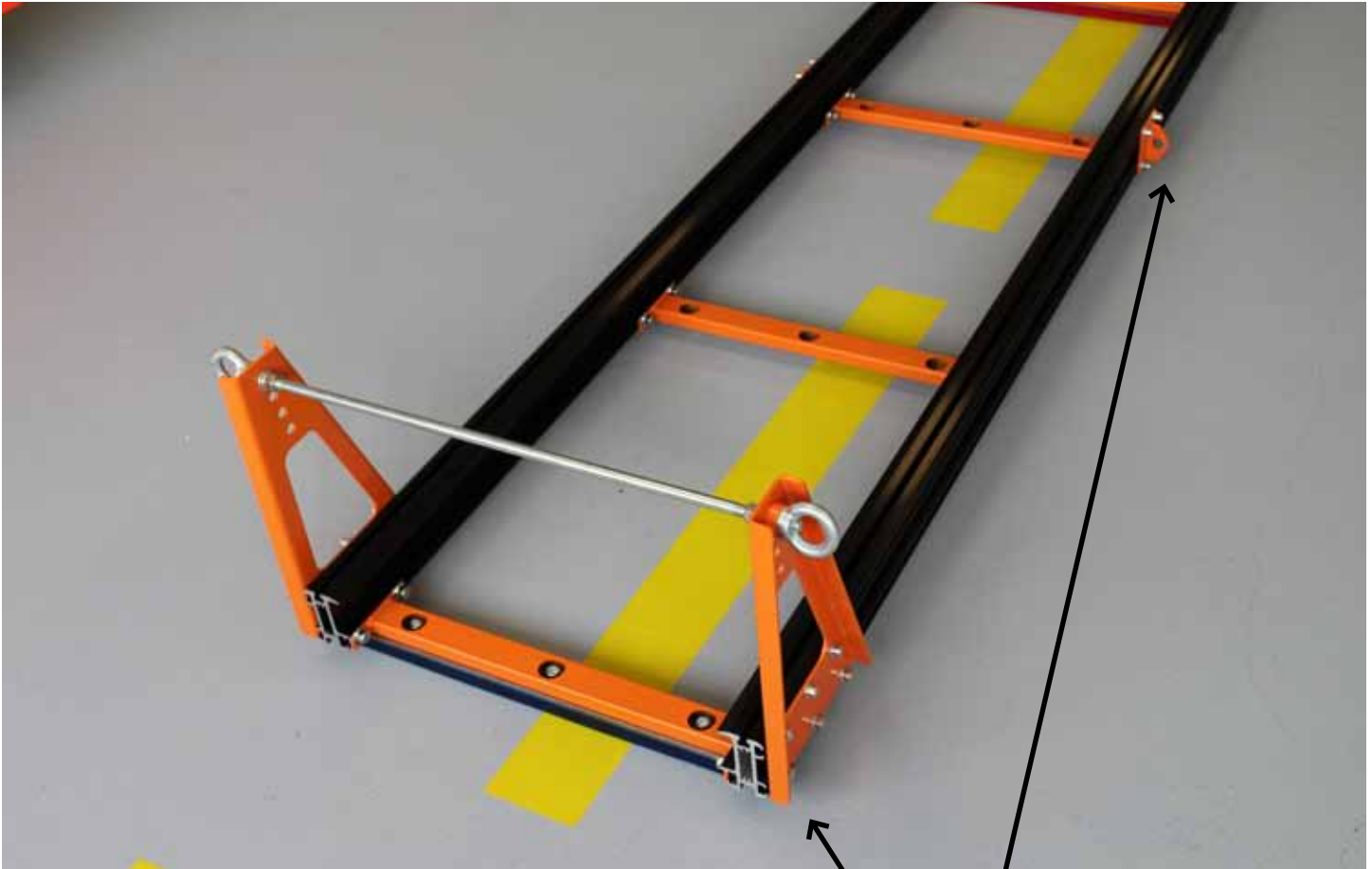

Brackets

CHECK

The assembly is finished. Check that all bolts are tight, on all pads and brackets.

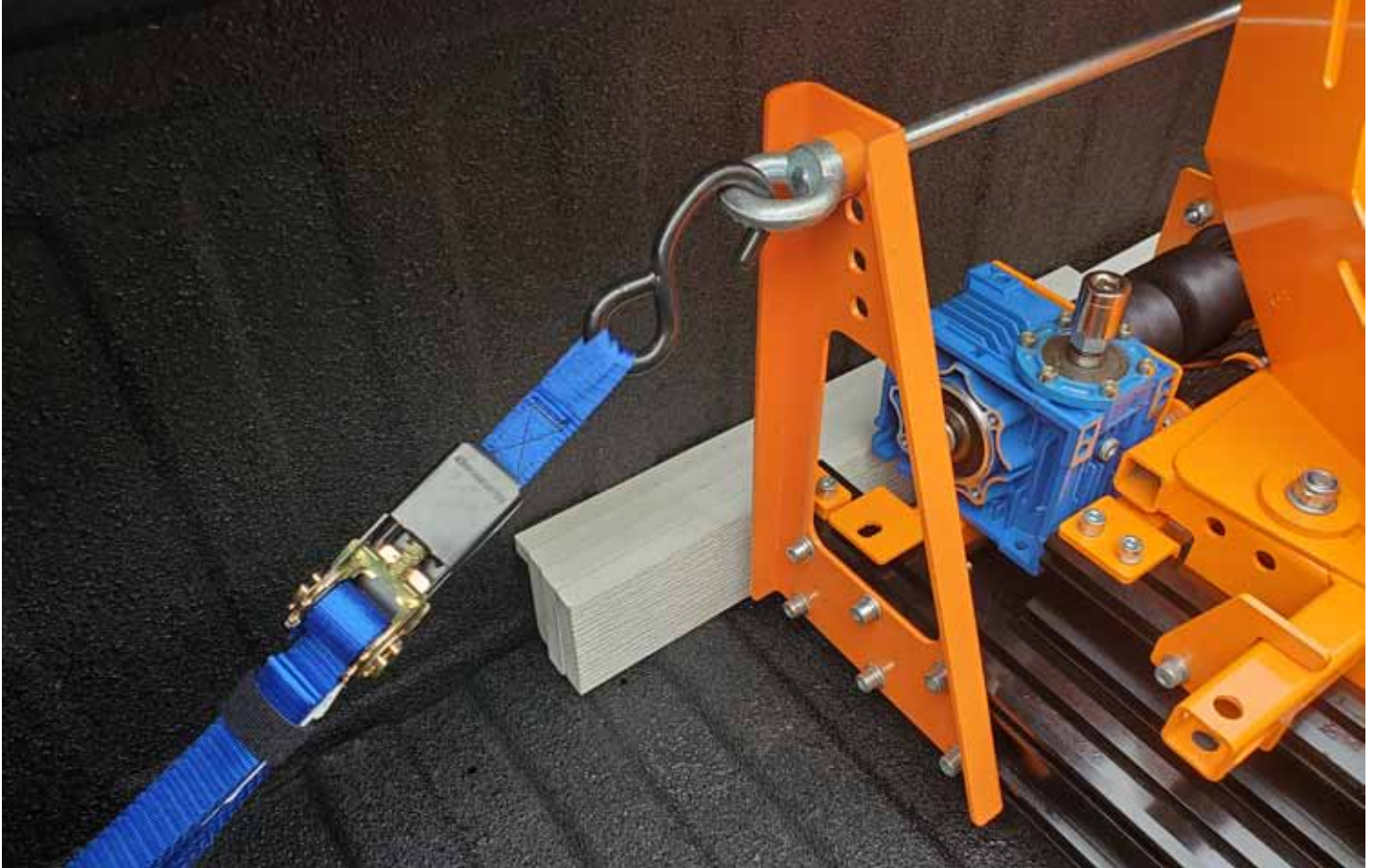

ATTACH STRAPS

First attach the front strap to the main brackets. Fasten the straps slightly. The client in the picture has placed a wooden spacer between the ramp and bulkhead - feel free to do the same or like on page 17.

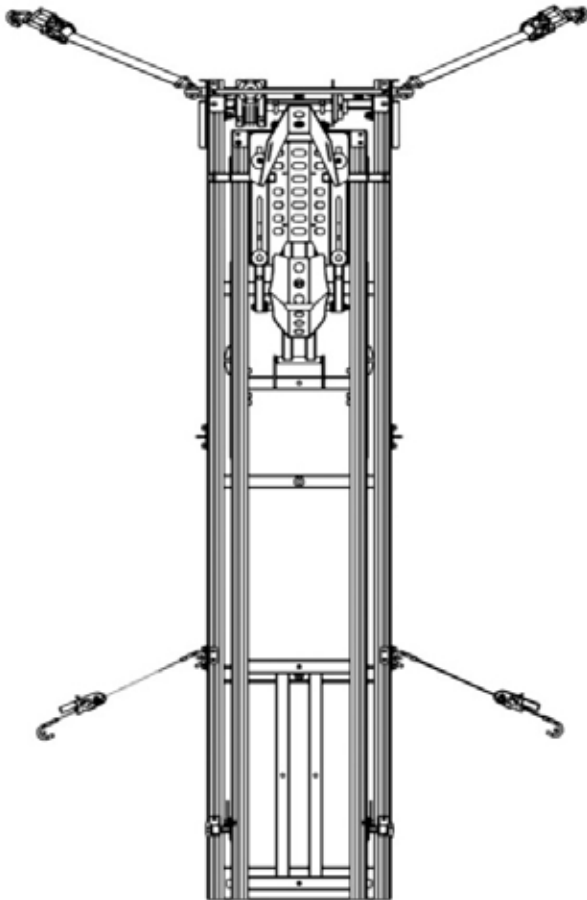

EXAMPLE - LONG BED TRUCKS AND VANS

If you have a cargo bed longer than the ramp itself, you can attach the strap brackets so that the straps form an X. By tightening front straps vs rear straps, you can choose the position of the ramp inside the cargo bed.

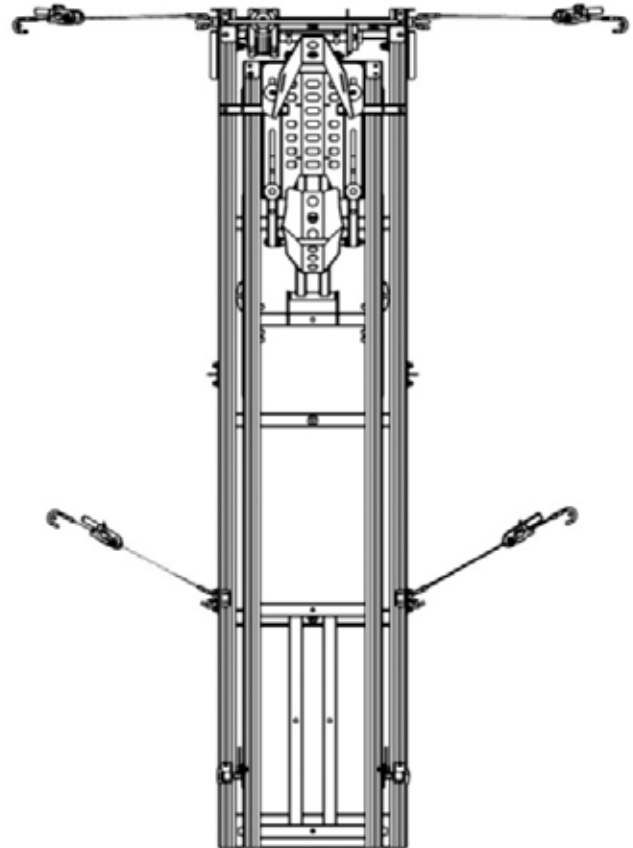

EXAMPLE - SHORT BED TRUCKS AND CREW CABS

For these vehicles the front of the ramp will press against the bulkhead. Slide the side brackets backwards a bit so that when the straps are tightened, it forces the ramp forward, against the bulkhead of the vehicle.

POSITION SIDE BRACKETS TO TIE DOWN IN X-PATTERN

Choose the X pattern suitable for your truck. The straps should form an X pattern, so that it cannot move either forwards or backwards. For short bed trucks you might not be able to form the X, so therefore slide the side brackets backwards a bit. When you tighten the straps then it will push the ramp into the cargo bed wall. First tighten the side straps, then the front straps.



EXAMPLE - USE SAME ANCHOR POINT

You can also use twin straps on the same anchor point to prevent the ramp from moving forward/backward, or to position the ramp where you want it on the cargo bed.



BLUE PAD

RED PAD

PAD PLACEMENT IN PICK-UP TRUCKS

The rear blue pad should rest on the tailgate, at its rear end. The red pad should rest on the edge of the cargo bed, just before the gap between the cargo bed and tailgate.

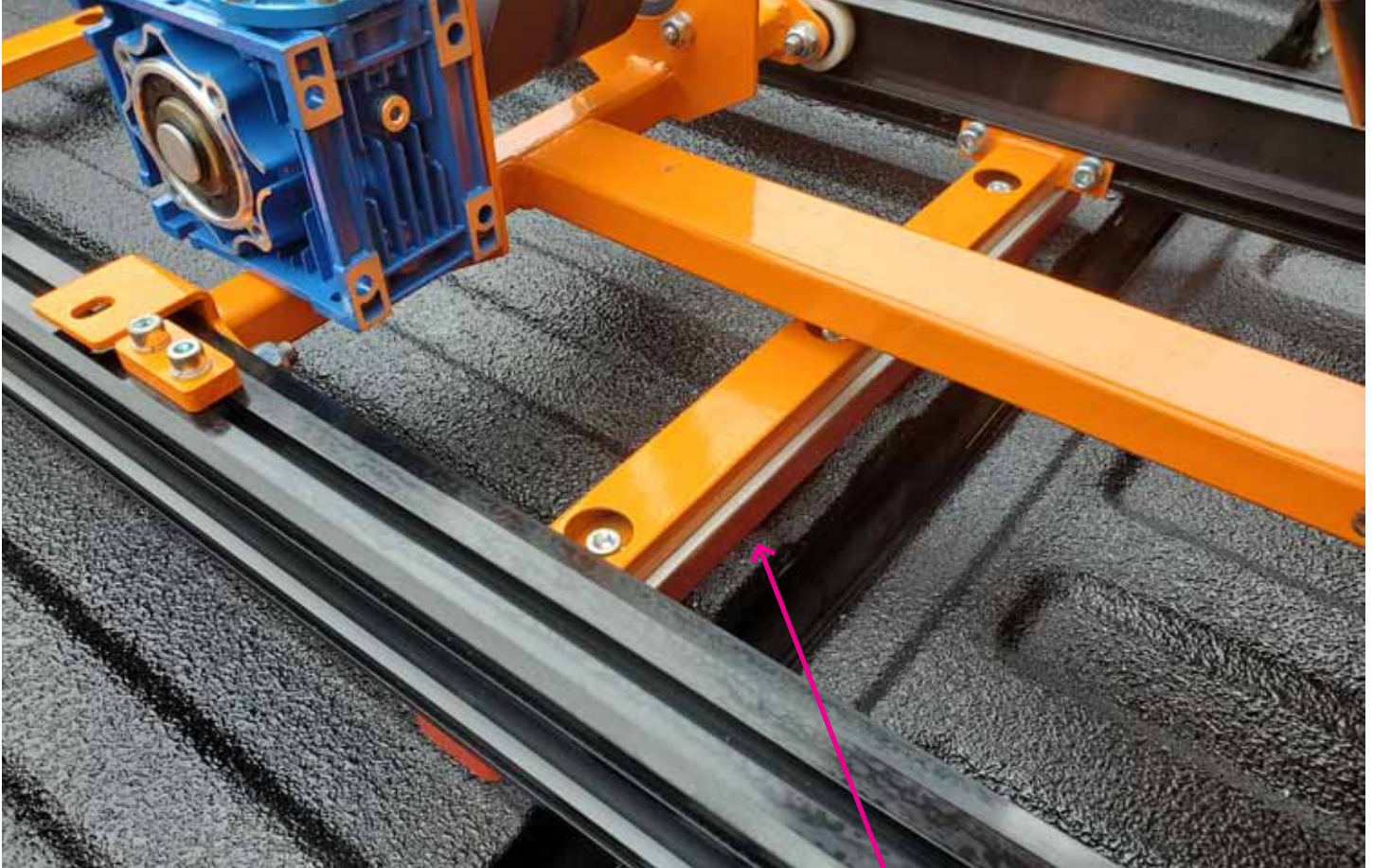

RED PAD

EXAMPLE - PAD PLACEMENT

You can loosen the bolts on the joiner that holds the red pad and slide it so that the pad sits on the cargo bed, close to the gap between the cargo bed and tailgate.

